

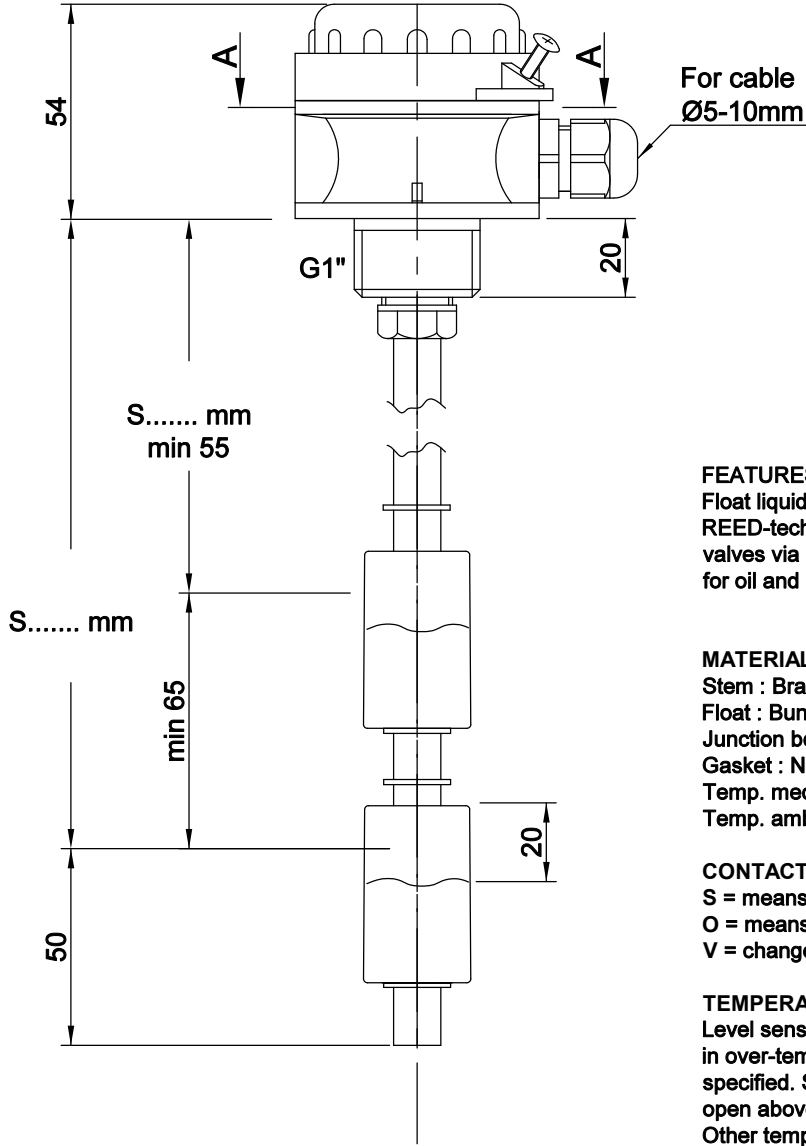

Ground

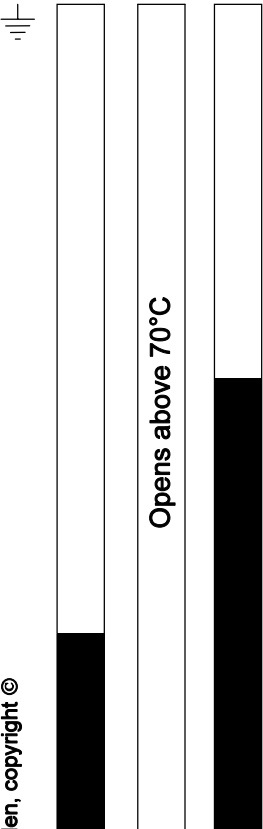

For cable Ø5-10mm

**FEATURES**  
 Float liquid level sensor with REED-technology to activate pumps or valves via relays or PCs. Recommended for oil and petroleum fluids.

**MATERIALS**  
 Stem : Brass  
 Float : Buna-N (nitrofuel), S.G. 0,42  
 Junction box : Polyamid 6  
 Gasket : Nitrile  
 Temp. media : -20...+100°C  
 Temp. ambient : -20...+70°C

**CONTACT SYMBOLS**  
 S = means NC low, NO going upwards  
 O = means NO low, NC going upwards  
 V = change over

**TEMPERATURE SWITCH**  
 Level sensors may be equipped with built in over-temperature protection, if specified. Standard temperature switches open above +70°C and reset at +50°C. Other temperature settings or closing of contacts and tighter tolerances upon request.

**PROTECTION DEGREE**  
 Junction box : IP67  
 Stem : IP68

**ELECTRICAL DATA**

Contact rating *	70 VA
max voltage	3-230 VAC/DC
max current	1,5 A

\* = resistive load  
 No ground = max 50 V

Note. Above values are for resistive loads. Mechanical life is 30 millions. Use series resistor for lamp load, or other suitable protection for inductive loads if the rating is higher than 1/10 of the values above.

Rights to the design and drawing belongs to HEMOMATIK Sweden, copyright ©

■ = Switch closed  
 □ = Switch open

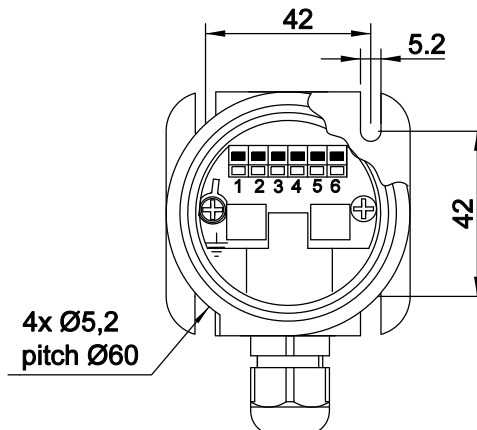

Section A-A