

Contact-Duo-Profile

3100.0118

Functional description of the system

The evaluation electronics monitor the safety strip, which is equipped with a terminating resistor and operates using the closed circuit principle. An amount of current defined by the resistance (8.2 kΩ) flows through the safety strip. When mechanical pressure causes the resistance in the safety strip to drop below 5.5 kΩ, this is recognised as an actuation (evaluation electronics: LED RED). When contact resistance or a broken cable raises the resistance in the safety strip above 11.5 kΩ, this condition is recognised as a broken cable and/or fault (evaluation electronics: LED YELLOW). In both cases, the system stops (evaluation electronics: safety relays K1 and K2 open).



Contact-Duo 3100.0118

Contact-Duo-Profile	
Article no.	3100.0118
Material	EPDM
Weight	0.259 kg/m
Shore hardness	Conductive mixture: 62+/-5 Shore A Non-conductive mixture: 60+/-5 Shore A
Interconnection	Series connection electr. max. 10 switching strips
Min. and max. length of the switching strip	0.1 m to 100 m
Storage temperature	-10°C to +15°C respectively +25°C (DIN 7716)
Delivery length	30 m
Response time of the evaluation electronics	< 12 ms

Certified characteristic data	
Actuation force	28 N bei 200 mm/s
Actuation angle (α)	+/-45°
Ineffective border area	0 mm, 30 mm with finger safety
Finger safety	yes
Max. operating speed	200 mm/s
Climatic conditions	-10°C to +55°C
Level of protection	IP67
Number of switching cycles	≥ 10,000 Switching cycles

Deformation travels	
Test temperature	20°C
Speed	200 mm/s
Actuation force	28,0 N
Pre-travel at max. operating speed	6.0 mm
Working travel 600N	10.0 mm
Compensation travel at 250 N	4.0 mm*
Compensation travel at 400 N	6.0 mm*

* Reduction because of recovery

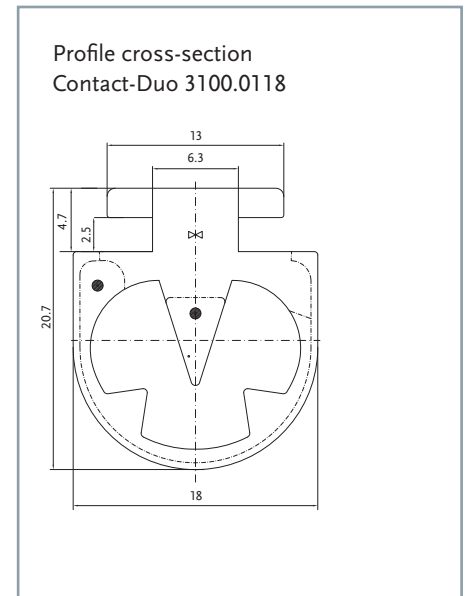

For dimensions without tolerance particulars, tolerance-free dimensions as per DIN ISO 3302-1 E2 shall apply.

You can choose any of several different variants for compatible evaluation signals (Category 1/PL c and Category 3/PL e, SIL3).